

Web-Based Information and Monitoring System of Cagayan de Oro City Academy for International Education

JUN BRIAN P. TUBONGBANUA

<https://orcid.org/0000-0002-7571-0993>

jbtubongbanua@liceo.edu.ph

Liceo de Cagayan University
Cagayan de Oro City, Philippines

KWENCY MAYE V. DAHILAN

<https://orcid.org/0000-0001-9398-0447>

kwenox.dahilan@gmail.com

Liceo de Cagayan University
Cagayan de Oro City, Philippines

KAYEPRIL GEORGETTE A. SAGUN

<https://orcid.org/0000-0002-4330-1714>

kayepirilgeorgette@gmail.com

Liceo de Cagayan University
Cagayan de Oro City, Philippines

JHEREX L. RUIZ

<https://orcid.org/0000-0002-0507-7184>

mr.jherexruiz@gmail.com

Liceo de Cagayan University
Cagayan de Oro City, Philippines

Gunning Fog Index: 14.19 • Originality: 99% • Grammar Check: 99%
Flesch Reading Ease: 32.60 • Plagiarism: 1%



ABSTRACT

The study aimed at providing the Cagayan de Oro Academy for International Education with a web-based information and monitoring system capable of carrying out school transactions of the Cagayan de Oro Academy for International Education. An online information and monitoring system is complex and flexible and is designed to meet distinct needs. In developing the proposed system, the researchers used the Prototyping Life Cycle Model. These applications improved the traditional transaction processing systems. Staff finds it tedious in searching and preparing reports on student's information and also laborious due to repetition of processes done in filling and updating of records. The proposed system caters posting and viewing of grades, class schedules, students, guardians and staff profiling and other important data needed in the system. The Web-based Information and Monitoring System is an expansion of a basic information system achieved through system design of an improved or broader capability by functionally or technically relating two or more information systems. With this, the academy will be able to provide quality service to its students. This thesis study offers important implication for monitoring and information of the school and lessen the workload of school management and save time.

KEYWORDS

Web-based, Information, System, School, Cagayan de Oro, Philippines

INTRODUCTION

We are now in the twenty-first century, the century of high-tech and advanced technology. Technology is a great contributor to the well-being of humankind. Thus, this work attempts to address the evolution of a new pathway of acquiring information through the internet from the use of, for example, connected portable devices instead of paper-based school record system, a shift that alters basic relationship between students and administrators (Holdren, (2008).

Technology plays a role as a helping aid in man's innovation for a productive lifestyle and success (Tidd, Bessant, & Pavitt, 2005). Moreover, the researchers introduce an innovation in the form of a web-based information and monitoring system acquired through system designs that are combined by two or more sub-systems. Importantly, these systems will make complex systems to a simple one. According to Forman (2007), carrying on with innovation in applied sciences can result in organizational changes that vary from the improvement of everyday operation and for convenient entry it supplies for the users.

Many schools such as Metropolitan Academy School, STI College – Recto and Santos Memorial National High School are still using a traditional process in computing grades, which is very time-consuming. An online grading, scheduling, and pre-enrollment system are a highly must-have addition to the educational drive-kit, especially when it provides a more effective, timely outcome and less effort. In lieu of this, the researchers aim to deliver a fast technology regarding not just only online grading system but also to online monitoring and information of the school and students (Resnick, (2002).

The proposed system is intended for the Cagayan de Oro Academy for International Education (CDO AIE). Taking into account that this institution is a newly established school, everything starts from scratch. The possible challenges that this school will face sooner is the management of the increasing amount of information both from the students and employees. Acquiring data or information, especially grades and schedules, memorandums, other important data that are usually in the school archives; hence, schools will come across an increasing amount of printed copies (O’Neil & Comley, (2010).

Moreover, schools store complete records of everyday transactions of the different departments. Maintaining and retrieving information done manually and stored in hard copies could be time-consuming and taxing (Kerrigan & Law, 2003).

The proposed system study would provide the target school with a more reliable, faster and more efficient information management system.

FRAMEWORK

Primarily, the goal of this study was to design and develop a web-based information and monitoring system that would improve the storage and monitoring of the website of the school. On this note, the researchers decided to use the Transform and Conquer Algorithm for this study, which is an algorithm that works as two-stage procedure. First, the problem is modified to be more amenable to a solution. In the second stage, the problem is solved.

The proposed system has one major module: the information system. Under this module, there are also sub-modules: online student and employee profiling, online scheduling and online grading for the teachers, and pre-enrolment for the students.

The Transform-and-Conquer paradigm is a powerful problem-solving strategy. The important thing to success is to be ready to view the problem from specific perspectives and to be equipped to look similarities between the predicament to be solved and some other challenge, not necessarily in the equal area. The better understanding and the easier chances to effectively observe the change into-and-overcome paradigm.

OBJECTIVES OF THE STUDY

General Objective

Mainly, the study sought to create a web-based information and monitoring system of (CDO AIE) Cagayan de Oro Academy for International Education.

Specific Objectives

Specifically, the study sought to attain the following objectives:

- To provide online monitoring of the parents or guardians including the academic standing their students through internet usage;
- To keep the parents and students updated on the events and announcements of the school;
- To provide an online system for easy storage and retrieval of personal information of students and teachers, enrollment records, class schedules, grades, and student and guardian accounts;
- To create a means that would provide better service through online; and
- To provide a tool for faster report generation.

METHODOLOGY

Research Design

An online information and monitoring system is complex and flexible and is designed to meet distinct needs. In developing the proposed system, the researchers used the Prototyping Life Cycle Model.

The Prototyping Life Cycle Model is a type of System Development Life Cycle that fits to complicated and large type of systems like the integrated information system for which the development of the system involves designing, coding, testing and checking by the clients. This model suggests that making the program in advance would provide a better visual for the researchers. This model allows clients to give their feedback about the system, thus enabling the researchers to develop a more efficient system by applying the feedback.

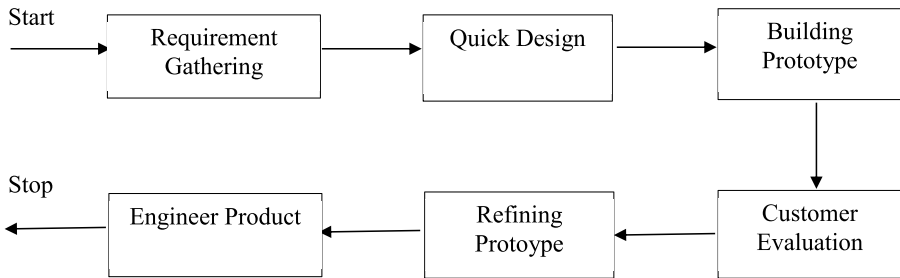

Figure 1. Prototyping Software Life Cycle Model

The development of the **Web-Based Information and Monitoring System of Cagayan de Oro Academy for International Education** followed the following phases:

1. **Requirement Gathering.** The researchers started by gathering information through an interview with the clients about their current system.
2. **Quick Design.** The researchers made a simple design for the program, focusing on the connections of information and transactions of the system, not on the actual process but how the process will function. The researchers analyzed and applied the design deemed most appropriate.
3. **Building Prototype.** After designing, the researchers built a prototype for each of the modules of the system, taking into consideration the application of the principles followed by the school.
4. **Customer Evaluation.** The researchers then presented the prototype to the clients for feedback.
5. **Refining Prototype.** The prototype will refine considering the client's feedback. However, the researchers had an option of going back to the quick design when the feedback of the client could affect the design of the system.

Research Setting

The integrated information system is design for the Cagayan de Oro Academy for International Education located in Kauswagan National Highway, Cagayan de Oro City.

Data Gathering

The researchers analyzed the current system of the enrollment of the Cagayan de Oro Academy for International Education.

Research Instruments

The needed requirements of the proposed system for CDO AIE were analyzed using the Unified Modeling Language (UML). The model of the data and data relationship was presented using the Entity Relationship Diagram. The system was develop in Cascading Style Sheet (CSS), JavaScript, Hypertext Markup Language (HTML), and PHP Hypertext Preprocessor for the front-end and MySQL for the back-end.

System Design

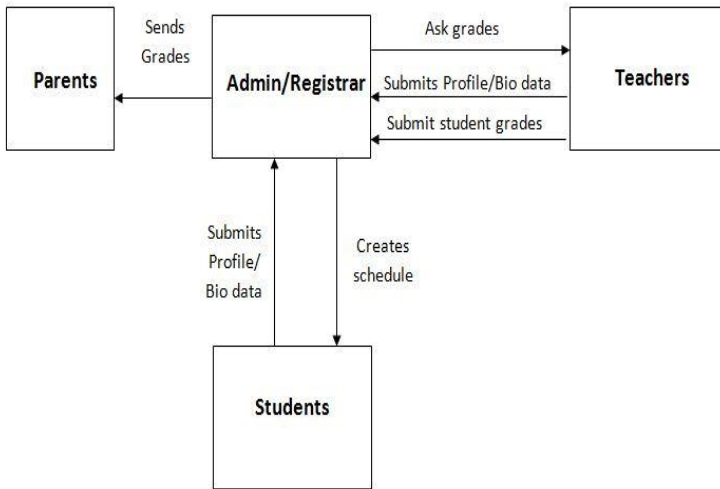

Figure 2. The Current System Flow Diagram

Narrative Description

The students and the teachers will submit their profiles/bio-data to the administrator/ registrar. The admin/registrar will then create the schedule of the enrolled students. After every quarterly exam, the teachers will submit the student grades to the admin/ registrar. Then, the parents go the school to claim the grades of their students to be distributed by the admin.

Proposed System

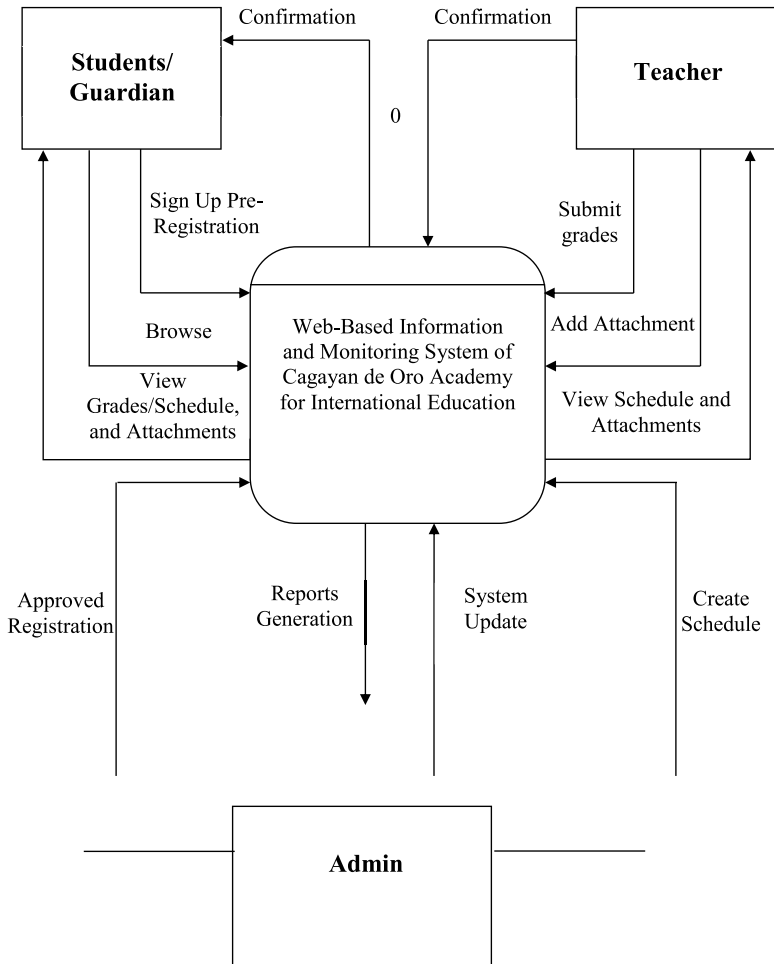

Figure 3. The Context Diagram of the Proposed System

Narrative Description of the Proposed System

The students and the guardians will sign up for a pre-registration of their accounts. The administrator will be the one to confirm the registration and provide them with their auto-generated ID number and password. The old students having accounts already may enroll by then. For new students, they must come to school with an ample time of just seven days to pay their tuition (May it be partial or full payment) as a part of the requirement to be officially enrolled. If not, the reservation will be deleted

automatically. The system will be able to generate reports such as the student grades, schedules, campus events and attachments, student, teacher and guardian profiles. The administrator will also be the one to input the list of schedules for the school year. On the teachers' side, they will be the one to input the grades to the system and the system will automatically compute the average grades of the students. However, only the administrator can update the grades whenever there are changes. The administrator is responsible for the maintenance of the system.

Entity-Relationship Diagram

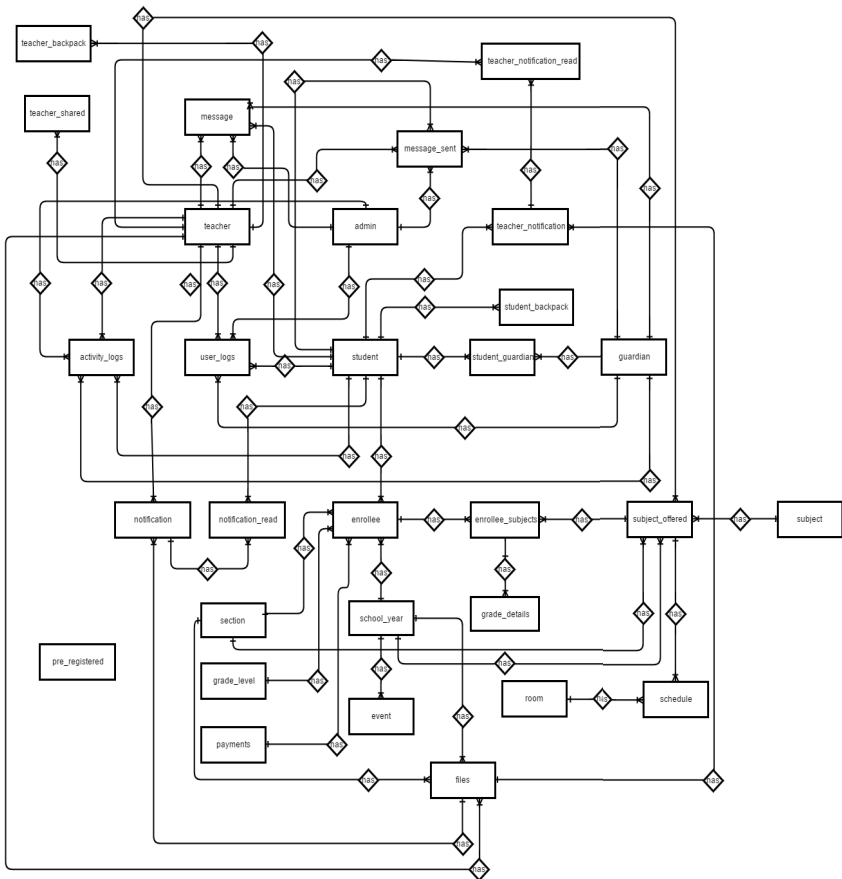

Figure 4. Entity-Relationship Diagram (ERD)

Database Structure

The system uses one database named `aie_db.sql`. The database contains many tables that store important records of Cagayan de Oro Academy for International Education like personal information of the students, guardians, and teachers records.

RESULTS AND DISCUSSION

Project Description, Requirements, and Specifications

ADD

Process Narrative

The add function can input the registration of user information, and the administrator can add student and providers. The users and admin can input the data to a specific field, and then the data inputted are saved.

Restriction/Limitation

The system does not accept records that contain incomplete and incorrect information, and each field must fill.

Performance Requirements

The function submits records of every user who has access to the web application.

Design Constraints

The system can track every activity a student, teacher, guardian, and admin and can evaluate the user's activity.

CONFIRM

Process Narrative

The confirm function confirms the registration of the users. The admin will send an email to the users' email address for official confirmation.

Restriction/Limitation

The system does not confirm registrations whose partial payment for enrollment is not perform.

Performance Requirements

The function confirms records of users registered the account to access the web application.

Design Constraints

The system can track every activity a student, teacher, guardian, and admin and can evaluate the user's activity.

EDIT/UPDATE

Process Narrative

Editing of the profile is applied to the users. The users manage his/her account. The administrator can only monitor it and have a report of it.

Restriction/Limitation

The administrator can add/remove providers in the system.

Performance Requirements

The function shall provide an option for canceling the changes or modifications made before such changes are save in the database.

Design Constraints

The user is the one who can only update/edit his/her information.

SEARCH

Process Narrative

The admin can search for users.

Restriction/Limitation

The search operation will only read strings. If the inputted value is a number, it will not search.

Performance Requirements

The function will match the text inputted in the text box to that in the database. If the text in the text box is not available or does not exist in the database, the system will display a message informing the user that the search cannot find.

Design Constraints

If any search requested has a result, a modification of the user will implement in the system.

CLEAR/DELETE

Process Narrative

The admin, the user, and the personnel can clear/delete text from a textbox.

Restriction/Limitation

If the user inputted incorrect information during registration, it would automatically clear the textboxes.

Performance Requirements

The system will automatically clear the textboxes if the user inputted incorrect information during registration.

Design Constraints

A modification is making whenever the admin, user or personnel clicks a clear/delete button.

Database Functional Description

Basic functions apply to all database tables.

Special Consideration

For a more efficient system, the system developers included the following special considerations:

1. A login form where users input their username together with their password for security purposes
2. Password Encryption is provide for a more secure accounts of the users
3. Monitoring of every user is activity logs

Audit Trial and Transaction Facility

The admin monitored the system to ensure the confidentiality of records. Every user must input his/her username and password to access the system. The user has limited access. Some of the records are intended for the administrator to view. All transactions of the users are save in the database.

CONCLUSION

The researchers developed a web-based information and monitoring system that offers an online posting of grades, viewing of grades, pre-enrolment of students, subject scheduling, profiling of user's accounts, update events and generates reports. The system can provide an online automated system for easy storage and retrieval of personal information such as enrollment records, class schedules, grades, and student and guardian accounts. It helps the users to provide better service through online.

RECOMMENDATIONS

Based on the findings of the system study, the following features are recommended for future system development:

- Online Enrolment
- Online Payment
- Android App

LITERATURE CITED

- Forman, C., Kauffman, R. J., Wu, D. J., & Bhargava, H. (2007). New research perspectives on mobility, organizations, systems and technologies. *Information Technology and Management*, 8(2), 83-85. Retrieved on January 9, 2019 from <https://goo.gl/JsL8KQ>
- Holdren, J. P. (2008). Science and technology for sustainable well-being. *Science*, 319(5862), 424-434. Retrieved on January 21, 2019 from <https://goo.gl/8pMZEa>
- Kerrigan, S., & Law, K. H. (2003). Logic-based regulation compliance-assistance. In *Proceedings of the 9th international conference on Artificial intelligence and law* (pp. 126-135). ACM. Retrieved on January 21, 2019 from <https://goo.gl/wXm8Lq>

- O'Neil, F., & Comley, J. (2010). Models and management of student employees in an Australian university library. *Australian Academic & Research Libraries*, 41(2), 100-112. Retrieved on January 21, 2019 from <https://goo.gl/EPAfgU>
- Resnick, M. (2002). Rethinking learning in the digital age. Retrieved on January 21, 2019 from <https://goo.gl/xjXYs7>
- Tidd, J., Bessant, J., & Pavitt, K. (2005). *Managing innovation integrating technological, market and organizational change*. John Wiley and Sons Ltd. Retrieved on January 21, 2019 from <https://goo.gl/JsuxYv>